

Available Finishes / Materials:

EG -- Electro-galvanized

Standard Finish: EG

Uniform load rating 250 lbs. [1.11kN] when mounted on 12 gauge channel

Catalog Number	Wt. lbs	L		H	
		in	mm	in	mm
BR8L0600EG	0.58	6	152.4	2 ⁷ / ₈	73.0
BR8L0800EG	0.83	8	203.2	2 ⁷ / ₈	73.0
BR8L1000EG	1.14	10	254.0	2 ⁷ / ₈	73.0
BR8L1200EG	1.49	12	304.8	3 ⁷ / ₁₆	87.3
BR8L1400EG	1.74	14	355.6	3 ¹⁵ / ₁₆	100.0
BR8L1600EG	2.25	16	406.4	4 ⁷ / ₁₆	112.7
BR8L1800EG	2.55	18	457.2	4 ¹⁵ / ₁₆	125.4

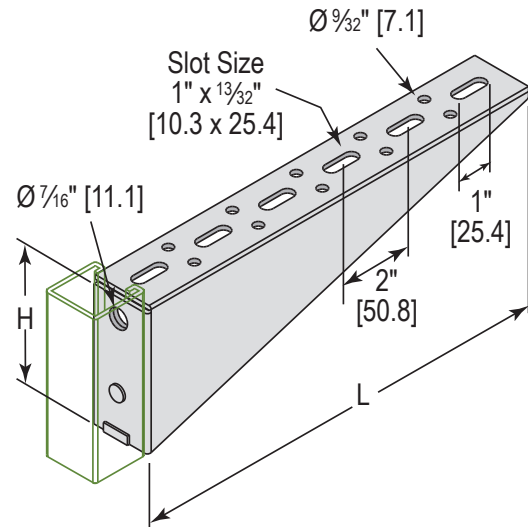

Material is 1⁵/₈" [41.3] wide x 1/4" [6.3] thick unless specified. Holes are 9/16" (14.3) diameter, 13/16" [20.6] center to edge on 1⁷/₈" [47.6] centers unless specified.

Material Specifications and Finishes

Carbon Steel – ASTM A1011-00 SS GR 33 or ASTM A1011-00CS Type B

EG – Electro-Galvanized. Electroplating deposits zinc on the surface of the steel by electrolysis from a bath of zinc salts. Recommended for relatively dry indoor use. This is the standard coating for most Phoenix products. Thickness of applied zinc is between 0.2 mils to 0.5 mils [5.1 μm to 12.7 μm]. Coatings on Phoenix EG products meet ASTM B633 SC1 Type III.

Note: Specifications subject to change without notice.

Project:	Date:	Phone:
Submitted By:	Address:	
Comment		