

Available Finishes / Materials:

EG -- Electro-galvanized

S4 -- 304 stainless steel

Standard Finish: EG

Stainless steel ball bearings

Bearings not to be lubricated

Note: Plate also available in stainless steel

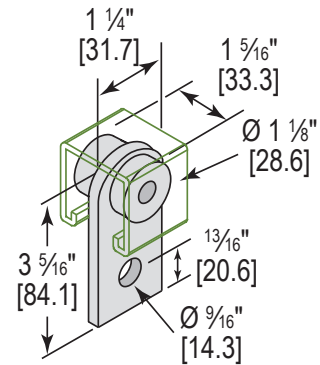

Catalog Number: R10 0000EG

Weight: 0.46 Lbs.

FPM	RPM	Design Load in 12 Ga. Channel	
		Lbs	kN
180	600	150	0.67
90	300	225	1.00
30	100	437	1.94

Material Specifications and Finishes

Carbon Steel – ASTM A1011-00 SS GR 33 or ASTM A1011-00CS Type B

EG – Electro-Galvanized. Electroplating deposits zinc on the surface of the steel by electrolysis from a bath of zinc salts. Recommended for relatively dry indoor use. This is the standard coating for most Phoenix products. Thickness of applied zinc is between 0.2 mils to 0.5 mils [5.1 μm to 12.7 μm]. Coatings on Phoenix EG products meet ASTM B633 SC1 Type III.

S4 – 304 Stainless Steel – ASTM A240 (Type 304)

Note: Specifications subject to change without notice.

Project:	Date:	Phone:
Submitted By:	Address:	
Comment		