

Available Finishes / Materials:

- VG -- Phoenix Vanguard
- PG -- Pre-Galvanized zinc

Standard Finish: VG

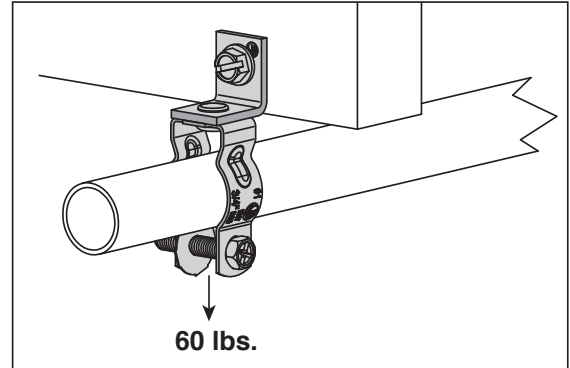
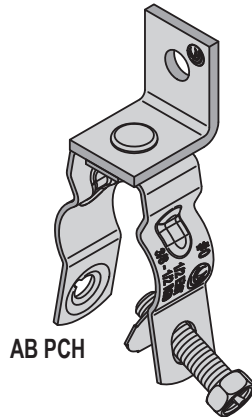

- **AB PCH:** Supports horizontal runs of conduit through metal studs and prevents conduit from rattling in wall.
- Conduit clip rotates 360 degrees.
- Suitable for air handling spaces (plenums) (remove washer at assembly)
- Retained combo head screw allows Robertson, Phillips/Slotted and Hex drivers.
- **Material:** Steel
- **Finish:** Pregalvanized

Catalog No.	Trade Size	Conduit Size		Hole Size	Box Qty
		EMT	Rigid		
AB PCH0	0	1/2"	3/8", 1/2"	9/32"	50
AB PCH1	1	3/4"	3/4"	9/32"	50
AB PCH2	2	1"	1"	9/32"	50

### Material Specifications and Finishes

**Spring Steel:**

Cold Roll, ASTM A684 Grade 1055 Spring Steel

**VG – Phoenix Vanguard**

Phoenix Vanguard coating is a multi-step process that meets the 1000 hour salt spray test per ASTM B117 and DIN 50021. **Vanguard coating is WEEE, ELV and RoHS compliant.** VG Finish is approved for wet and dry applications. It is a chrome free three step coating system that combines an inorganic zinc-rich basecoat with an aluminum-rich organic topcoat.

Carbon Steel – ASTM A1011-00 SS GR 33 or ASTM A1011-00CS Type B

**PG – Pre-Galvanized zinc**

ASTM A653 G-90 Pre-galvanized zinc is produced by continuously rolling steel coils or sheets through molten zinc at the mills. The coils or sheets are slit to size and fabricated by forming, shearing or punching to produce the finished product. During fabrication cut edges are not generally zinc coated; however, the zinc near the uncoated metal becomes a sacrificial anode to protect the bare areas.

Note: Specifications subject to change without notice.

<b>Project:</b>	<b>Date:</b>	<b>Phone:</b>
<b>Submitted By:</b>	<b>Address:</b>	
<b>Comment</b>		